

**Title: DAQ V1.0 Pin Diagrams**

**Project:** Hybrid Sky Data Capture System, Version 1.0

**Date:** August 26, 2008

**Author:** Stephen Daniel

**1. Introduction**

This document contains the pin-outs for all ICs in the V1 implementation of the data capture board. This information is gathered from various data sheets and is used to verify the schematics and PC layout.

The chips are referred to by their part numbers as shown in the schematic.

**2. Support Chips**

This first section contains all transistors and all ICs except for the microprocessor.

**LT1114 Quad Precision Op Amp**

This chip is used as U1 through U3 and U5.

<b>Pin</b>	<b>Signal</b>
1	OUT A
2	-IN A
3	+IN A
4	V+
5	+IN B
6	-IN B
7	OUT B
8	OUT C
9	-IN C
10	+IN C
11	Ground
12	+IN D
13	-IN D
14	OUT D

## LT1167 Precision Differential Amplifier

This chip is U4.

Pin	Signal
1	Gain resistor
2	-IN
3	+IN
4	Ground
5	REF
6	OUT
7	Vdd
8	Gain resistor

## LT1029A Precision Regulator

This chip is U6 and U7.

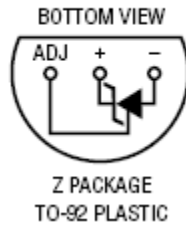

## LT1121-3.3 Regulator

This chip is U8.

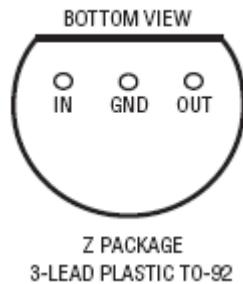

## LTC1293 Analog to Digital Converter

This chip is U9.

Pin	Signal
1	CH 0
2	CH 1
3	CH 2
4	CH 3
5	CH 4
6	CH 5
7	COM
8	Digital ground
9	V-
10	Analog ground
11	Vref
12	Din
13	Dout
14	CS
15	CLK
16	Vcc

## LT1121-5 Regulator

This chip is U11.

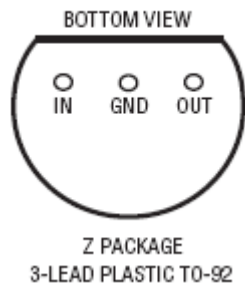

### DS1302 Time of Day

This chip is U12

Pin	Signal
1	Vcc2 (+5)
2	Xtal
3	Xtal
4	Ground
5	Chip Select
6	I/O
7	CLK
8	Vcc1 (Capacitor)

### H11L1M Schmitt-Trigger Opto-Isolator

This chip is U13 and U14.

Pin	Signal
1	Input Anode
2	Input Cathode
3	NC
4	Output
5	Ground
6	Vcc

### 2N3904 NPN Amplifier

This is Q1.

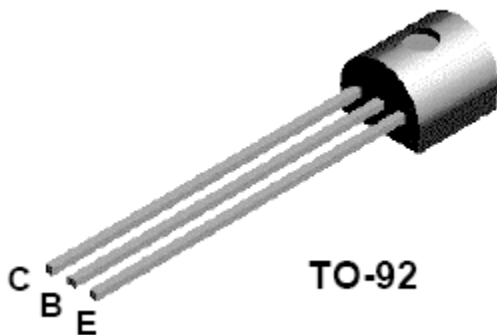

## 2N3906 PNP Amplifier

This is Q2.

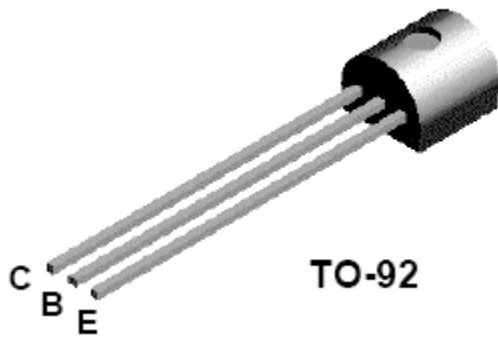

### 3. PIC Microprocessor

This section contains the PIC pin-out plus some discussion on how the pins were set up.

#### PIC 18F2455 Microprocessor

This chip is U10.

Pins 1-14 are on the left side of the chip, presumed to face towards the analog side of the board. Pins 28-15 are on the right side of the chip and are used for digital functions.

PIC Pin	Signal Name	External Pin	Function
1	MCLR		Wired to an "execute mode" push button (inverted)
2	RA0		Input from mode select switch
3	RA1		Record/stop switch
4	RA2		Output to red LED
5	RA3		Output to green LED
6	RA4		Raw pin0 to outside world
7	RA5	ADC 15	Clock to A/D
8	VSS		VSS
9	OSC2		Crystal
10	OCS2		Crystal
11	RC0	ADC 14	Chip select to A/D
12	RC1	ADC 13	Data from A/D
13	RC2	ADC 12	Data to A/D
14	Vusb		.022 uf cap

PIC Pin	Signal Name	External Pin	Function
28	RB7		Opto-isolated digital input 1
27	RB6		Opto-isolated digital input 0
26	RB5		Raw pin to outside world 1
25	RB4	TOD 5	Chip select to TOD chip
24	RB3	TOD 6	Data to/from DS1302 TOD chip
23	RB2	TOD 7	Clock to TOD chip
22	SCK	SD 5	Clock to SD memory card
21	SDI	SD 7	Data from SD
20	VDD		VDD (5 volts)
19	VSS		VSS
18	SDO	SD 2	Data to SD
17	RC6	SD 1	Chip select to SD
16	D+		Data to/from USB
15	D-		Data to/from USB

## **External Connections**

- MCLR MCLR is an inverted signal. Should be held high, pushing button brings it to logic 0.
- RA0 Mode select switch is a rotary switch with multiple positions. The switch is wired with 10K resistors to act like a crude potentiometer between VSS and VDD. Center tap comes out to the PIC pin.
- RA1 Record/Stop switch is SPST. In "stop" mode the switch is open and the signal is logic 0 (pulled down through a 10K resistor). In record mode the switch is closed, and the signal is logic 1.
- RA2,3 The LEDs are directly driven from the PIC, which provides 5 volts at up to 25 milliamps.
- RA4, RB5 Raw pins come out to a screw terminal. The terminal should be a pair, pin and ground. If the pin is not in use then a wire should connect the pin to ground.

## 4. External Connectors

Most of the external connectors are simple screw terminals. However there are two connectors that are more complex whose pin-outs are provided here.

### SD Memory Card Connector

This chip is connector SD1.

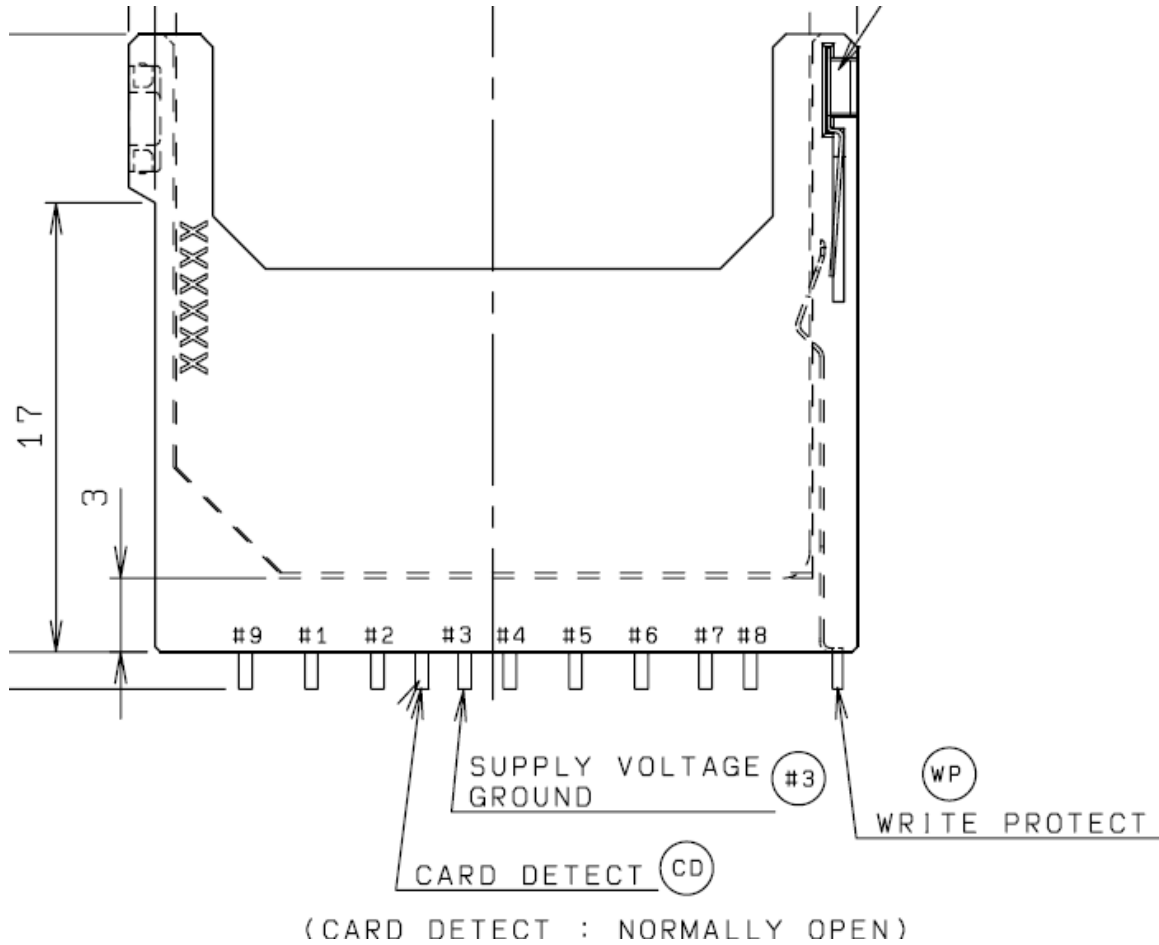

Pin	Signal
1	Chip Select
2	Data In (to SD card)
3	Ground
4	VDD
5	CLK
6	Ground
7	Data Out
8	Not used
9	Not used

### USB Type B Connector

This chip is connector USB1.

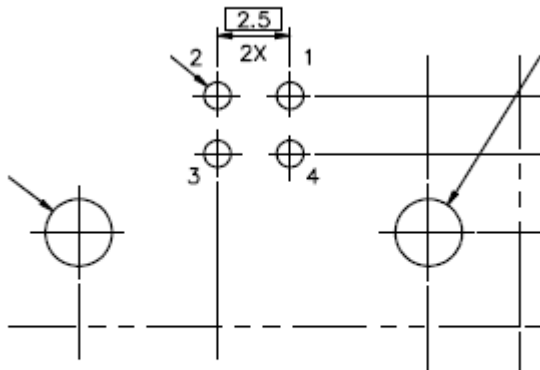

### P.C. BOARD LAYOUT

This is shown with the USB receptacle pointing down.

Pin	Signal
1	VBUS
2	D-
3	D+
4	Ground