

Note: All components on this page are 1% tolerance.

Hybridsky.com

DAQ Filters

Evan Daniel

Rev 1.0

2/23/2009

Page 1

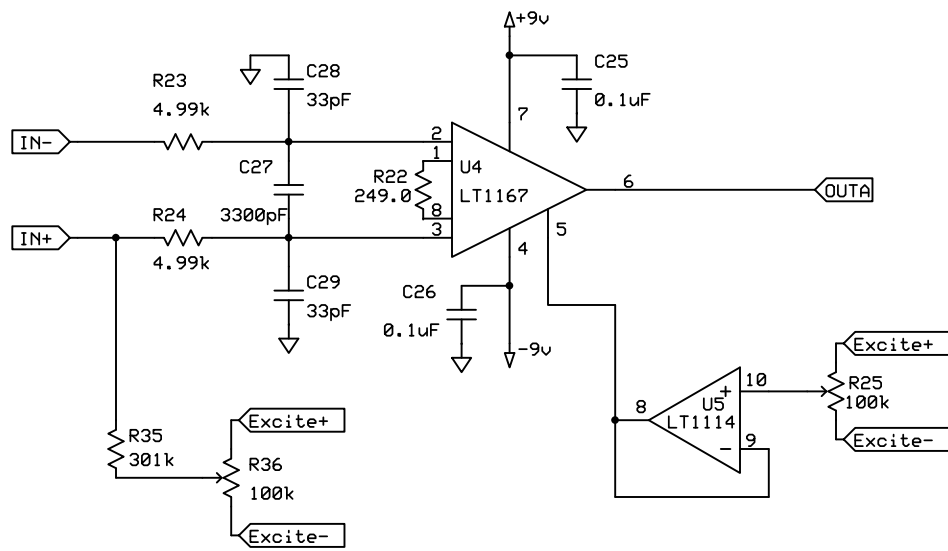

R22: 0.1% precision resistor, select for gain
 C27-C29: C0G 5%
 R28, R33: 1%, Low TC
 R35, R36: optional sensor offset adjust
 R28, R30, R32, R33: optional excite V adj. Install only if high precision V meter available

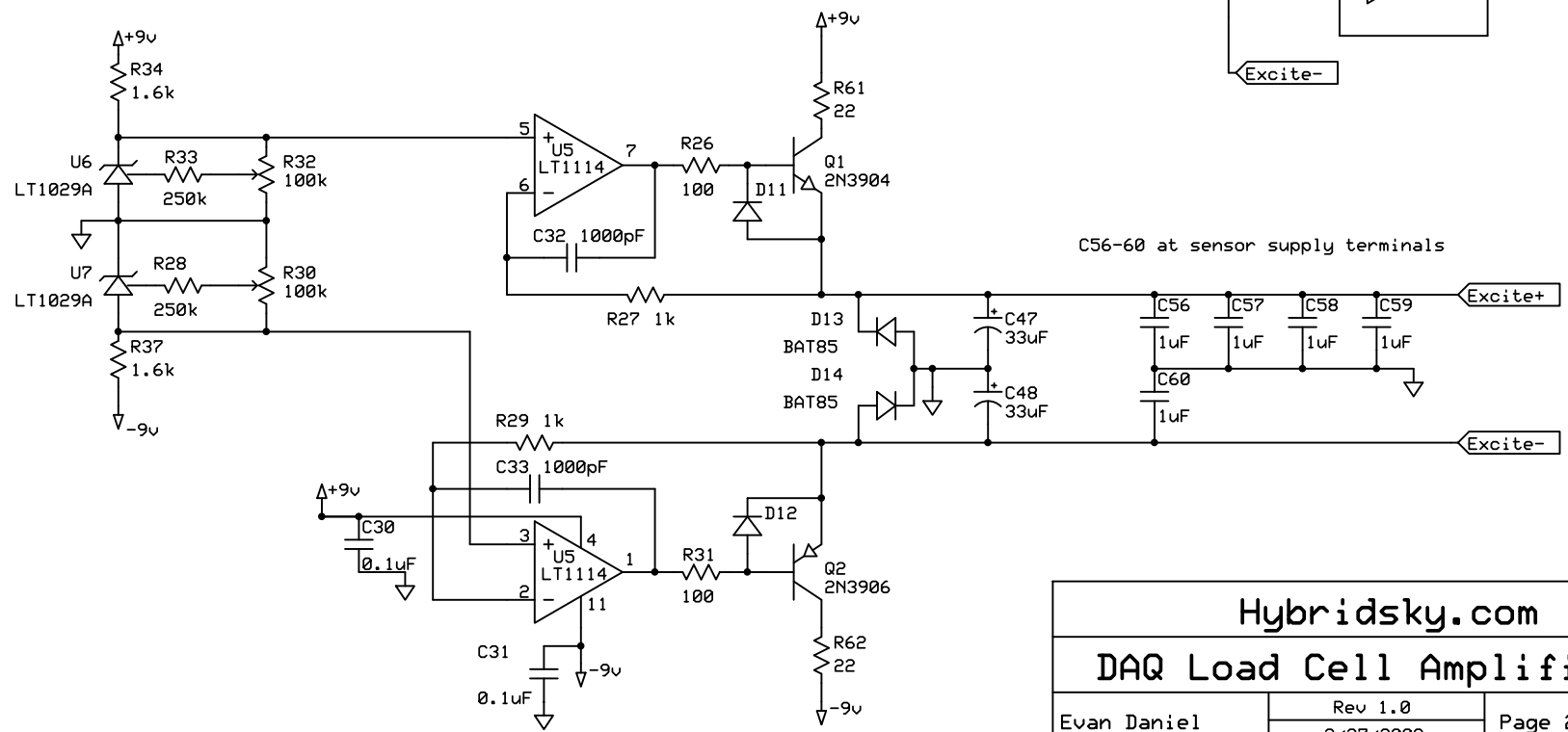
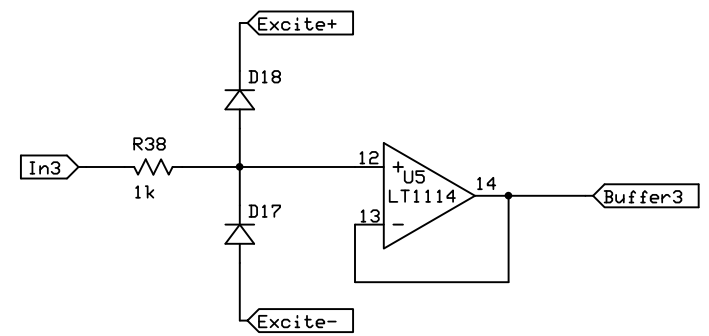

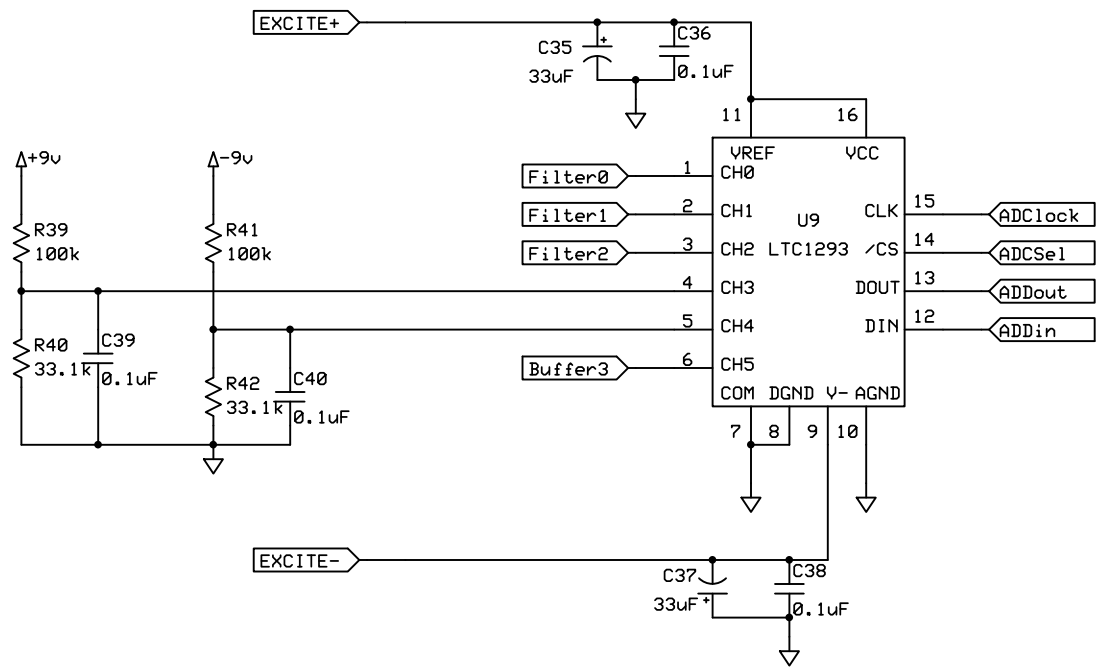

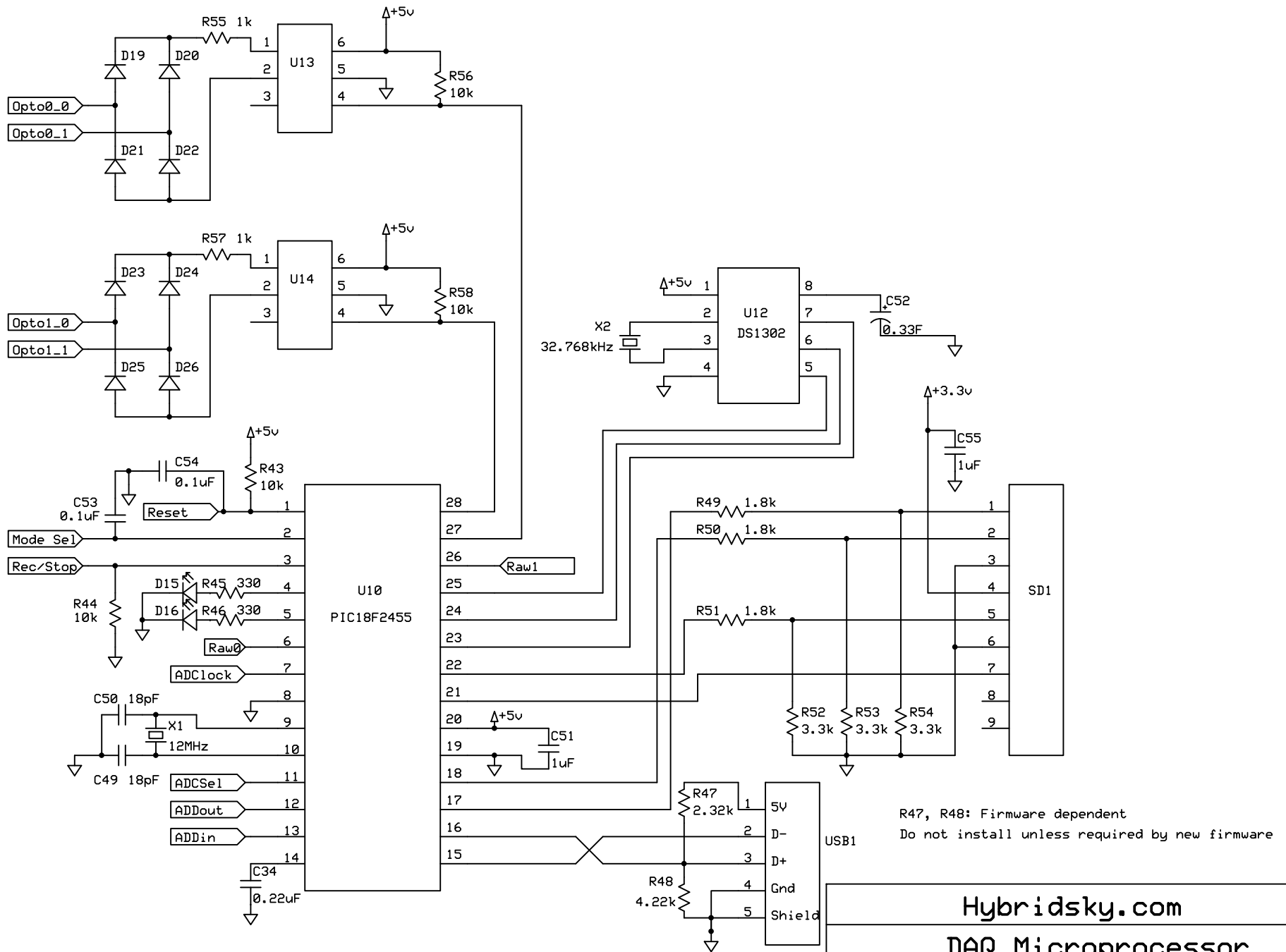

R47, R48: Firmware dependent
Do not install unless required by new firmware

| | | |
|---------------------------|-----------|--------|
| Hybridsky.com | | |
| DAQ Microprocessor | | |
| Designer's name | Rev 1.0 | Page 4 |
| | 3/28/2008 | |

